



XTI 180P

XTI 180P-DV

INVERTER WELDER

Instructions for use

ISSUE 1

XTI 180P INVERTER – USER INFORMATION

WARNING

Operation and maintenance of arc welding equipment can be dangerous and hazardous to your health.

To prevent possible injury, read, understand and follow all warnings, safety precautions and instructions before using the equipment

GASES AND FUMES

Gases and fumes produced during the arc welding/cutting process can be dangerous and hazardous to your health.

Keep all fumes and gases from the breathing area.

Keep your head out of the welding fume plume.

Use an air-supplied respirator if ventilation is not adequate to remove all fumes and gases.

The kinds of fumes and gases from the arc welding/cutting depend on the kind of metal being used, coatings on the metal, and the different processes. You must be careful when cutting or welding any metals which may contain one or more of the following:

Antimony, Chromium, Mercury, Arsenic, Cobalt, Nickel, Barium, Copper, Selenium, Beryllium, Lead, Silver, Cadmium, Manganese, Vanadium

Always read the safety data sheets (SDS) that should be supplied with the material you are using. These SDS will give you information regarding the kind and volume of fumes and gases that may be dangerous to your health.

Use special equipment, such as water or down draft welding/cutting tables, to capture fumes and gases.

Do not use the welding torch in an area where combustible or explosive gases or materials are located.

Phosgene, a toxic gas, is generated from the vapours of chlorinated solvents and cleansers. Remove all sources of these vapours.

ELECTRIC SHOCK

Electric shock can injure or kill. The arc welding process uses high voltage electrical energy. This electric energy can cause severe or fatal shock to the operator or others in the workplace.

Never touch any parts that are electrically “live”

Wear dry gloves and clothing. Insulate yourself from the work piece or other parts of the welding circuit.

Repair or replace all worn or damaged parts.

Extra care must be taken when the workplace is moist or damp.

Disconnect power source before performing any service or repairs.

FIRE AND EXPLOSION

Fire and explosion can be caused by hot slag, sparks, or the arc weld.

Be sure there is no combustible or flammable material in the workplace. Any material that cannot be removed must be protected.

Ventilate all flammable or explosive vapors from the workplace.

Do not cut or weld on containers that may have held combustibles.

Consult the site safety officer before working in areas where fire hazards exist.

Do not cut aluminum alloys underwater or on a water table unless the hydrogen gas Can be eliminated or dissipated. Trapped hydrogen gas that is ignited will cause an explosion.

NOISE

Noise can cause permanent hearing loss. Arc welding/cutting processes can cause noise levels to exceed safe limits. You must protect your ears from loud noise to prevent permanent loss of hearing.

To protect your hearing from loud noise, wear protective ear plugs and/or ear muffs. Protect others in the workplace.

Noise levels should be measured to be sure the decibels (sound) do not exceed safe Levels.

ARC WELDING RAYS

Arc welding/cutting rays can injure your eyes and burn your skin. The arc welding/cutting Process produces very bright ultra violet and infra red light. These arc rays will damage your eyes and burn your skin if you are not properly protected.

To protect your eyes, always wear a welding helmet or shield. Also always wear safety glasses with side shields, goggles or other protective eye wear.

Wear welding gloves and suitable clothing to protect your skin from the arc rays and sparks.

Keep helmet and safety glasses in good condition. Replace lenses when cracked, chipped or dirty.

Protect others in the work area from the arc rays. Use protective booths, screens or shields.

GENERAL DESCRIPTION

This welding machine is manufactured using advanced inverter technology. The input voltage is rectified to DC and then inverted to high frequency AC voltage. This allows the use of a much smaller transformer and so allowing weight saving and improved power efficiency.

INSTALLATION

LOCATION

Be sure to locate the machine according to the following guidelines:

- In areas, free from moisture and dust, ambient temperature between 0 degrees ° to 40 degrees °.
- In areas, free from oil, steam and corrosive gases.
- In areas, not subjected to abnormal vibration or shock.
- In areas not exposed to direct sunlight or rain.
- Place at a distance of 12" (304.79mm) or more from walls or similar that could restrict natural airflow for cooling.

CONNECTION OF POWER SUPPLY CABLE

Warning:

Parweld advises that this equipment be electrically connected by a qualified electrician.

Connect the power supply cable to the required voltage. The primary cable should be connected to the correct size of socket to avoid arcing or over heating. Ensure the power supply is sufficiently rated to match the machines maximum output (refer to specification table on machine).

Operate the welding power source from a single-phase 50/60 Hz, ac power supply. The input voltage must match one of the electrical input voltages shown on the input data label on the unit nameplate. The XT1180-dv machine will automatically detect and switch between 110 and 230v single phase. The XT1180 machine should only be used on 230v supply. Refer to the specifications table for voltage tolerances.

Connect the end of earth (green) conductor to a suitable earth. Use a grounding method that complies with all applicable electrical regulations

Explanation of controls

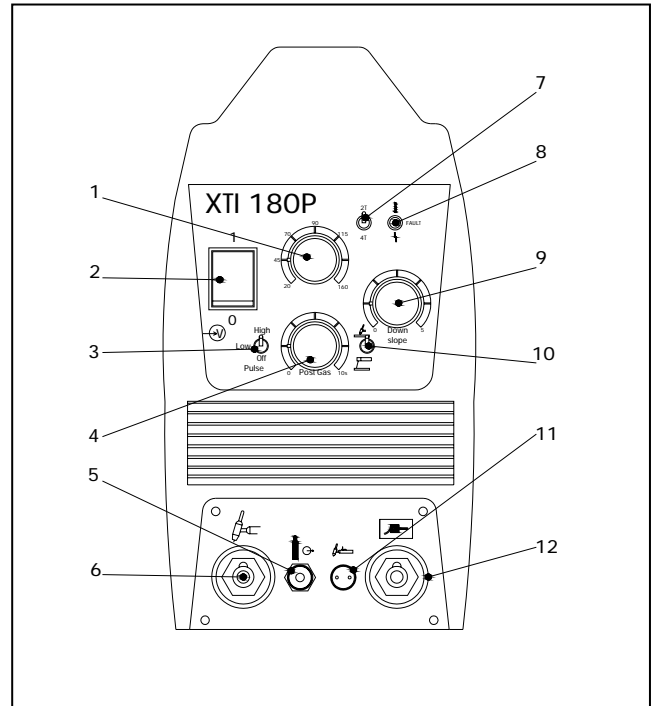

- 1) **Output power control** for adjustment of the power out put of the machine in TIG or MMA mode.
- 2) **ON OFF Switch** for switching on or off the mains supply to the machine. Note in MMA mode the output of the machine is permanently on unless the on/off switch is in the off position.
- 3) **Pulse control switch** switches on the current pulsing function when in TIG welding mode the low setting gives a pulse frequency of 2 Hz and the high setting gives a pulse frequency of between 200hz.
- 4) **Post gas time** This controls the time of the post flow gas after the welding current has switched off and is adjustable between 0 and 10 seconds.
- 5) **Gas outlet** Connection for TIG welding gas outlet 3/8 BSP male.
- 6) **Output power connection (Torch)** this is the 50mm Dinse connection socket for the TIG torch or MMA electrode holder.
- 7) **Trigger latching** This selector switch determines the operating mode of the trigger switch on the TIG torch. In the 2T position the operator must press and hold down the trigger button on the welding torch for as long as he needs the welding power to stay on. In the 4T position the operator presses and releases the trigger once to start the welding operation and presses and releases again to stop the welding operation, it is therefore not necessary to keep the trigger depressed during welding.
- 8) **Fault light** This indicates a fault or over temperature condition with the machine refer to the fault finding section for further information.
- 9) **Down slope time** The down slope time is adjustable between 0 and 5 seconds and is activated when in the TIG welding mode. The downslope function decreases the welding current from the preset output to 5amps over the time selected on the dial.
- 10) **Function selector switch.** Selects TIG operating mode or MMA mode, in the MMA mode the welding output is latched on and all the TIG welding functions disabled. In the TIG welding position all the additional TIG welding functions are active.

- 11) **Trigger socket** This is the connection point for the torch trigger which starts and stops the welding cycle when in TIG welding mode
- 12) **Workpiece connection** This is the 50mm Dinse connection socket for the workpiece return lead which should be connected to the part to be welded, ensuring good electrical contact.

Connection of torches and operation

Wide safety margins provided by the coil design ensure that the welding power source will withstand short-term overload without adverse effects.

The welding current range values should be used as a guide only. Current delivered to the arc is dependent on the welding arc voltage, and the process selected. The operator should use the welding current range values as a guide, and finally adjust the current setting to suit the application.

CAUTION:

Before connecting torch and cables to the machine make sure the primary power supply is switched off. Remove any packaging material prior to use. Do not block the air vents at the front or rear or sides of the welding power source.

MMA cable connections

Connect work lead to work lead socket 11. (Negative terminal)
Connect electrode lead to the torch outlet socket 6. (Positive terminal), insert an electrode in the holder switch the machine on. Use the control knob to adjust the require output current
Commence welding

MMA WELDING GUIDE

Electrode polarity

MMA electrodes are generally connected to the torch terminal and the work lead to the work piece terminal
But if in doubt consult the electrode manufacturer's literature.

Effects of stick welding various materials

High tensile and alloy steels

The two most prominent effects of welding these steels are the formation of a hardened zone in the weld area, and, if suitable precautions are not taken, the occurrence in this zone of under-bead cracks. Hardened zone and under-bead cracks in the weld area may be reduced by using the correct electrodes, preheating, using higher current settings, using larger electrodes sizes, short runs for larger electrode deposits or tempering in a furnace.

Manganese steels

The effect on manganese steel of slow cooling from high temperatures is to embrittle it. For this reason it is absolutely essential to keep manganese steel cool during welding by quenching after each weld or skip welding to distribute the heat.

Cast iron

Most types of cast iron, except white iron, are weldable. White iron, because of its extreme brittleness, generally cracks when attempts are made to weld it. Trouble may also be experienced when welding white-heart malleable, due to the porosity caused by gas held in this type of iron.

Copper and alloys

The most important factor is the high rate of heat conductivity of copper, making preheating of heavy sections necessary to give proper fusion of weld and base metal.

Types of electrodes

Arc welding electrodes are classified into a number of groups depending on their applications. There are a great number of electrodes used for specialized industrial purposes which are not of particular interest for everyday general work. These include some low hydrogen types for high tensile steel, cellulose types for welding large diameter pipes, etc. The range of electrodes dealt with in this publication will cover the vast majority of applications likely to be encountered; are all easy to use and all will work on even the most basic of welding machines.

Metals being joined & electrode comments

Mild steel

6013 ideal electrodes for all general purpose work. Features include outstanding operator appeal, easy arc starting and low spatter.

Mild steel

7014 all positional electrode for use on mild and galvanized steel furniture, plates, fences, gates, pipes and tanks etc. Especially suitable for vertical down welding.

Cast iron

99% nickel suitable for joining all cast irons except white cast iron.

Stainless steel

318I-16 high corrosion resistance. Ideal for dairy work, etc. On stainless steels.

BASIC TIG WELDING GUIDE

Tig welding cable connection

Connect the TIG torch to the torch terminal and the work lead to the work terminal for direct current straight polarity. Direct current straight polarity is the most widely used polarity for dc tig welding. It allows limited wear of the electrode since 70% of the heat is concentrated at the work piece. Connect the gas hose on the TIG torch to the gas outlet on the front panel of the machine and the control lead plug to the 2 pin socket on the front panel of the machine.

TIG welding guide ranges

Electrode diameter	dc current (amps)
0.040" (1.0mm)	30 – 60
1/16" (1.6mm)	60 – 115
3/32" (2.4mm)	100 – 165

Tungsten electrode types

Electrode type Welding application

Thoriated 2% dc welding of mild steel, stainless steel and copper. Excellent arc starting, long life, high current carrying capacity.

Ceriated 2% dc welding of mild steel, stainless steel, copper, aluminium, magnesium and their alloys longer life, more stable arc, easier starting, wider current range, narrower more concentrated arc.

Guide for selecting filler wire diameter

Filler wire diameter	dc current range
1/16" (1.6 mm)	20 - 90
3/32" (2.4 mm)	65 - 115
1/8" (3.2 mm)	100 - 165
3/16" (4.8 mm)	200-350

The filler wire diameter specified is a guide only, other diameter wires may be used according to the welding application.

Shielding gas selection

Alloy	shielding gas
Aluminium & alloys	argon
Carbon steel	argon
Stainless steel	argon
Nickel alloy	argon
Copper	argon
Titanium	argon

ROUTINE MAINTENANCE

The only routine maintenance required for the power supply is a thorough cleaning and inspection, with the frequency depending on the usage and the operating environment.

Warning

Disconnect primary power at the source before removing the cover. Wait at least two minutes before opening the cover to allow the primary capacitors to discharge.

To clean the unit, remove the screws securing the outer cover, lift off the outer cover and use a vacuum cleaner to remove any accumulated dirt and dust. The unit should also be wiped clean, if necessary; with solvents that are recommended for cleaning electrical apparatus.

TROUBLE SHOOTING

TIG welding problems

Weld quality is dependent on the selection of the correct consumables, maintenance of equipment and proper welding technique.

edges of weld		
Weld bead too wide and flat or undercut at edges of weld or excessive burn through	Welding current is too high color code	Decrease weld current
Weld bead too small or insufficient penetration or ripples in bead are widely space apart	Travel speed too fast	Reduce travel speed
Weld bead too wide or excessive bead build up or excessive penetration in butt joint	Travel speed too slow	Increase travel speed
Uneven leg length in fillet joint	Wrong placement of filler rod	Re-position filler rod
Electrode melts when arc is struck	Electrode is connected to the '+' terminal	Connect the electrode to the '-' terminal
Dirty weld pool	(a) Electrode contaminated through contact with work piece or filler rod material (b) Gas contaminated with air	(a) Clean the electrode by grinding off the contaminates (b) Check gas lines for cuts and loose fitting or change gas cylinder
Electrode melts or oxidizes when an arc is struck	(a) No gas flowing to welding region (b) Torch is clogged with dust (c) Gas hose is cut (d) Gas passage contains impurities (e) Gas regulator is turned off (f) Torch valve is turned off (g) The electrode is too small for the welding current	(a) Check the gas lines for kinks or breaks and gas cylinder contents (b) Clean torch (c) Replace gas hose (d) Disconnect gas hose from torch then raise gas pressure to blow out impurities (e) Turn on (f) Turn on (g) Increase electrode diameter or reduce the welding current
Poor weld finish	Inadequate	Increase gas flow

Description	Possible cause	Remedy
Excessive bead build up or poor penetration or poor fusion at	Welding current is too low	Increase weld current and/or faulty joint preparation

	shielding gas	or check gas line for gas flow problems
Arc flutters during TIG welding.	(a) Tungsten electrode is too large for the welding current (b) Absence of oxides in the Weld pool.	(a) Select the right size electrode. Refer to basic TIG welding guide. (b) Refer basic TIG welding guide for ways to reduce arc flutter
Welding arc cannot be established	a) Connect the work clamp to the work piece or connect the work/torch leads to the right welding terminals (b) Torch lead is disconnected (c) Gas flow incorrectly set, cylinder empty or the torch valve is off	(a) Work clamp is not connected to the work piece or the work/torch leads are not connected to the right welding terminals (b) Connect it to the correct terminal (c) Select the right flow rate, change cylinders or turn torch valve on
Arc start is not smooth	(a) Tungsten electrode is too large for the welding current (b) The wrong electrode is being used for the welding job (c) Gas flow rate is too high (d) Incorrect shielding gas is being used (e) Poor work clamp connection to work piece	(a) Select the right size electrode (b) Select the right electrode type. Refer to basic TIG welding guide (c) Select the correct rate for the welding job. Refer to basic TIG welding guide (d) Select the right shielding gas. Refer to basic TIG welding guide (e) Improve connection to work piece

MMA welding problems

Description	Possible cause	Remedy
Gas pockets or voids in weld metal (porosity)	(a) Electrodes are damp (b) Welding current is too high. (c) Surface impurities such as	(a) Dry electrodes before use (b) Reduce welding current (c) Clean joint before welding

Crack occurring in weld metal soon after solidification commences	(a) Rigidity of joint. (b) Insufficient throat thickness. (c) Cooling rate is too high.	(a) Redesign to relieve weld joint of severe stresses or use crack resistance electrodes. (b) Travel slightly slower to allow greater build up in throat. (c) Preheat plate and cool slowly.
A gap is left by failure of the weld metal to fill the root of the weld	(a) Welding current is too low (b) Electrode too large for joint. (c) Insufficient gap (d) Incorrect sequence	(a) Increase welding current (b) Use smaller diameter electrode. (c) Allow wider gap (d) Use correct build-up sequence
Portions of the weld run do not fuse to the surface of the metal or edge of the joint.	(a) Small electrodes used on heavy cold plate (b) Welding current is too low (c) Wrong electrode angle (d) Travel speed of electrode is too high (e) Scale or dirt on joint surface	(a) Use larger electrodes and preheat the plate (b) Increase welding current (c) Adjust angle so the welding arc is directed more into the base metal (d) Reduce travel speed of Electrode (e) Clean surface before welding.

Description	Possible cause	Remedy
Non-metallic particles are trapped in the weld metal (slag inclusion).	(a) Non-metallic particles may be trapped in undercut from previous run (b) Joint preparation too restricted (c) Irregular deposits allow slag	(a) If bad undercut is present, clean slag out and cover with a run from a smaller diameter electrode (b) Allow for adequate penetration and room for cleaning out the slag (c) if very bad, chip or grind out

	to be trapped.	Irregularities
	(d) Lack of penetration with slag trapped beneath weld bead.	(d) Use smaller electrode with sufficient current to give adequate penetration. Use suitable tools to remove all slag from corners
	(e) Rust or mill scale is preventing full fusion.	(e) Clean joint before welding.
	(f) Wrong electrode for position in which welding is done.	(f) Use electrodes designed for position in which welding is done, otherwise proper control of slag is difficult.

Fault lamp is on, no power output.	(a) Machine overheated (b) Over current state (c) Internal fault with machine	(a) Allow to cool with fan running (b) Switch off mains power to the machine and re start (c) Have a qualified service engineer inspect then repair the welder

Power source problems

Description	Possible cause	Remedy
The welding arc cannot be established	(a) The primary supply voltage has not been switched on (b) The welding power source switch is switched off (c) Loose connections internally	(a) Switch on the primary supply voltage (b) Switch on the welding Power source. (c) Have a qualified service engineer repair the connection
Maximum output welding current cannot be achieved with nominal mains supply voltage	Defective control circuit	Have a qualified service engineer inspect then repair the welder
Welding current reduces when welding	Poor work lead connection to the work piece	Ensure that the work lead has a positive electrical connection to the work piece
A total loss of power, pilot lamp is off, no output, the fan is not operating	(a) Failure of input voltage (b) Possible over voltage	(a) Re-establish mains supply (b) Check voltage and if necessary

EC DECLARATION OF CONFORMITY

Hereby we declare that the machines as stated below

Type: XTI 180P, XTI 180P-DV

Conform to the EC Directives: 73/23/EEC and
89/336/EEC

European standard: EN/IEC 60974-1

This is to certify that the tested sample is in conformity with all provisions of the above detailed EU directives and product standards.

Rohs Compliance Declaration

Directive 2002/95/ec of the European Parliament

Restriction of use of certain hazardous substances in
electrical and electronic equipment

Type: XTI 180P , XTI 180P-DV

The above listed products are certified to be compliant with the rohs directive with all homogeneous component parts being controlled to ensure material contents as per the list below.

Cadmium 0.01% by weight
Lead 0.1% by weight
Mercury 0.1% by weight
Hexavalent chromium 0.1% by weight
Polybrominated biphenyl's (pbbs) 0.1% by weight
Polybrominated diphenyl ethers (pbdes) 0.1% by weight

It should be noted that under specific exempted applications, where lead is used as an alloying element the following limits are applied in accordance with the regulations.

Copper and copper alloy parts use less than 4% by weight of each homogeneous component.

Steel and steel alloy parts use less than 4% by weight of each homogeneous component.

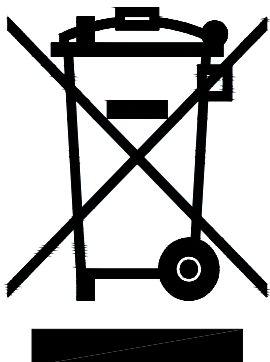

Aluminium and aluminium alloy parts use less than 4% by weight of each homogeneous component.

Only dispose off in authorised sites for electrical and electronic waste do not dispose of with general refuse or landfill waste.

STATEMENT OF WARRANTY

Limited Warranty:

Parweld Ltd, hereafter, "Parweld" warrants to customers of its authorized distributors that its products will be free of defects in workmanship or material. Should any failure to conform to this warranty appear within the time period applicable to the Parweld products as stated below, Parweld shall, upon notification thereof and substantiation that the product has been stored, installed, operated, and maintained in accordance with Parweld's specifications, instructions, recommendations and recognized standard industry practice, and not subject to misuse, repair, neglect, alteration, or accident, correct such defects by suitable repair or replacement, at Parweld's sole option, of any components or parts of the product determined by Parweld to be defective.

Parweld makes no other warranty, express or implied. This warranty is exclusive and in lieu of all others, including, but not limited to any warranty of merchantability or fitness for any particular purpose.

Limitation of Liability:

Parweld shall not under any circumstances be liable for special, indirect or consequential damages, such as, but not limited to, lost profits and business interruption. The remedies of the purchaser set forth herein are exclusive and the liability of Parweld with respect to any contract, or anything done in connection therewith such as the performance or breach thereof, or from the manufacture, sale, delivery, resale, or use of any goods covered by or furnished by Parweld whether arising out of contract, negligence, strict tort, or under any warranty, or otherwise, shall not, except as expressly provided herein, exceed the price of the goods upon which such liability is based. No employee, agent, or representative of Parweld is authorized to change this warranty in any way or grant any other warranty.

Purchaser's rights under this warranty are void if replacement parts or accessories are used which in Parweld's sole judgment may impair the safety or performance of any Parweld product.

Purchaser's rights under this warranty are void if the product is sold to purchaser by non-authorized persons.

The warranty is effective for the time stated below beginning on the date that the authorized Distributor delivers the products to the purchaser. Notwithstanding the foregoing, in no event shall the warranty period extend more than the time stated plus one year from the date Parweld delivered the product to the authorized distributor.